

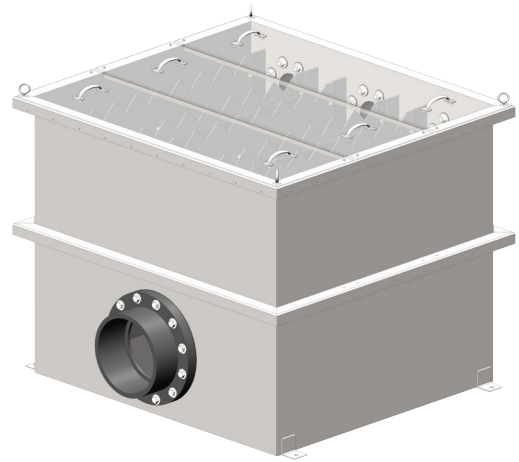

SPLITTER BOX

Make the most of your investment.

The AquaPyr® Splitter Box is designed to provide an economical solution for dividing the water flow between several AquaPyr® Ultra Low Waste Filters or other water treatment processes.



Offers flow splitting, isolation and diversion for filter feeding or other applications

- 304 or 316 SS or Epoxy Coated CS Tank
- SS Launderer/Adjustable V-Notch Weir Plates
- Schedule 80 PVC or CPVC Socket Connections
- 2" Polypropylene Bottom Drain
- Optional Wafer BF Isolation Valves

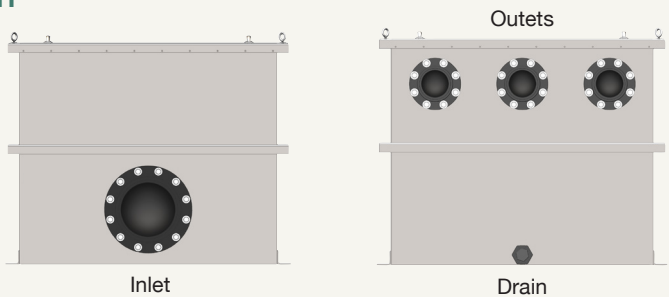

Choose from these three standard models or request a custom size.

Splitter Box	Model 300		Model 750		Model 2100	
Inlet Flow (gpm-m3/hr)	0-300	0-68	0-750	0-170	0-2100	0-477
Outlet Flow Each (gpm-m3/hr)	0-100	0-28	0-250	0-57	0-700	0-159
Dimensions* LxWxH (inches-mm)	44x43x35"	1118x1092x889	61x55x48"	1549x1397x1219	92x85x71"	2343x2159x1810
Inlet Pipe Size (Imperial-Metric)	8"	200NB	12"	300NB	16"	400NB
Outlet Pipe Size - X3 (Imperial-Metric)	4"	100NB	6"	150NB	10"	250NB
Drain (Imperial-Metric)	2"	50NB	2"	50NB	2"	50NB
Dry Weight (lbs-kg)	520	236	915	415	3400	1542
Operating Weight (lbs-kg)	2020	916	5815	2637	20080	9108
Power	No Power Required					

1-713-999-AQUA (2782) • info@aquapyr.com

*Information subject to change without notice.

